

Tamburin Stuttgart Mittwoch Class

10.10.2018

1 LE CAFE NOIR J32 · 2/4L

Peggy Hamilton: Chocolate & Champagne - Sacramento 25 · Crib: SCDDDB Contributed Cribs & Diagrams

- 1- 4 | 1s+2s chase clockwise once round
- 5- 8 | 1s+2s dance RH across
- 9-12 | 1s+2s dance LH across
- 13-16 | 1s+2s chase counter clockwise once round
- 17-20 | 1M+2L turn LH
- 21-24 | 1L+2M turn LH
- 25-32 | 1s+2s dance $\frac{3}{4}$ RL, 2s+1s set

2 GYPSY DREAMS S32 · 2/4L

Terry Glaspool: An Itch to Dance · Crib: E-cribs · Diagram: Keith Rose's Diagrams

- 1- | 1c cross RH and face down | 1c+2c $\frac{1}{2}$ LH turn on the sides ; all chase cclw one place | all turn P $\frac{3}{4}$ LH into a line across (W BtoB)
- 9- | Gypsy Pousette, as follows.
- 9-12 | (Box setting) All set R and swivel R $\frac{1}{4}$ »on the hop« to face away from P, all set L and swivel R $\frac{1}{4}$. to face in | all set R (M passing BtoB) and swivel R $\frac{1}{4}$, all set L and do not swivel. Partners finish facing away from each other but are not lined up BtoB.
- 13-16 | (Gypsy turn) All starting to their own R, dance around P halfway and melt into turn $\frac{3}{4}$ BH to finish facing P in a line across, M in the middle.
- 17- | Reel4 across the dance. On [24] the M dance $\frac{1}{4}$ around each other, Lsh to Lsh, **while{}** the W extend the loops to join P in promhold, all forming a line across, 1c facing up, 2c down.
- 25- | [25] 1c+2c Promenade $\frac{1}{4}$ around each other (M staying Lsh to Lsh), into the last 7 bars of the Tournée.

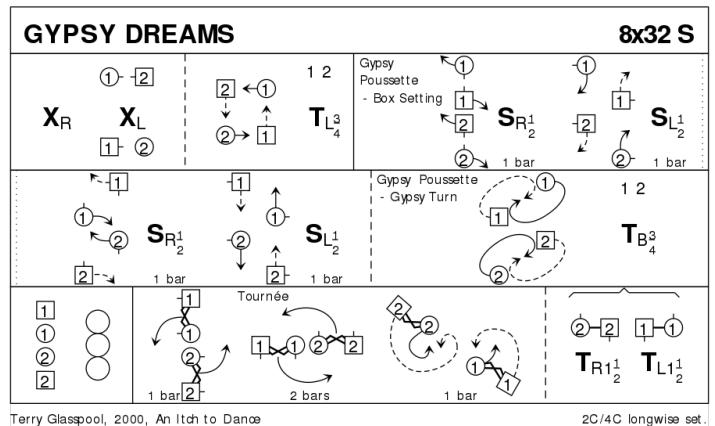

Notes: In [9-12] each C follows the edges of a square:
 Music: A smooth strathspey for example: »Birks of Invermay« by Tersipchore

3 ALLTSHELLACH S32 · 2/4L

Elizabeth D Gilroy: RSCDS XXIII 2 · Crib: E-cribs · Diagram: Keith Rose's Diagrams

- 1- 1c+2c set | turn BH, into ; 1c+2c ½Poussette, finishing in the middle, facing down
- 9- 2c+1c lead down the middle ; (2c divides) 1c+2c lead up to (1,2)
- 17- Reel4 across the dance, 1W and 2M pass Lsh to begin, and finish with a loop on own side
- 25- Tournée

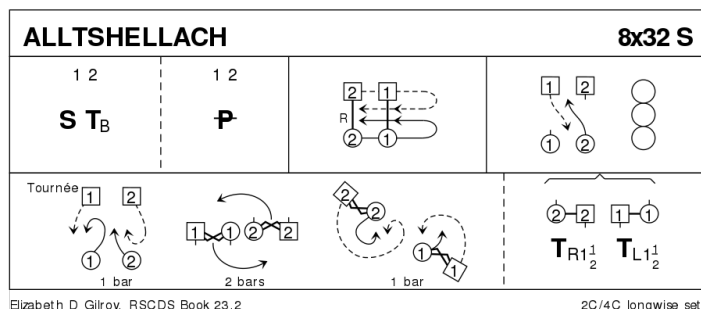

4 SWASHBUCKLING IAIN J32 · 2/4L

Carolyn Hunt: San Francisco Collection Volume 2 · Crib: E-cribs · Diagram: Keith Rose's Diagrams

- 1- 1M Reel3 with 1W+2W (Rsh to 2W)
- 9- 1M with 1W tenaciously following Reel3 with 2c (Rsh to 2M)
- 17- 1c dance down middle, 1M leading ; 1c lead back up RHJ, 2c step in on [24] for
- 25- 1c+2c allemande

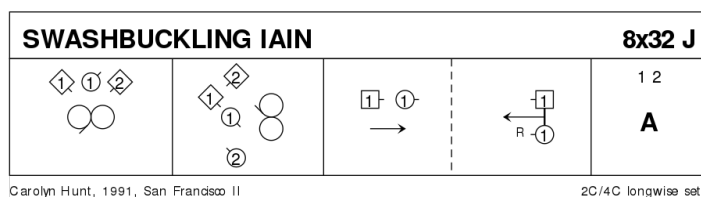

5 ST ANDREW'S NICHT J48 · 2RR

Scottish Dances collected by Mary Isdal MacNab · Crib: E-cribs

- 1- 1c+2c RHA ; LHA
- 9- Women cross RH, set to other M ; turn him LH
- 17- Women cross back, set to P ; turn P LH
- 25- Men advance with 2 PdB, set to each other ; swivel turns {4} to finish BtoB facing own P
- 33- Diagonal Reel4, ending in original places
- 41- 1c+2c Poussette to meet next couple.

24.10.2018

6 THE SILVER TASSIE S32 · 3/4L

John Drewry: The Leaflet Dances with Music · Crib: E-cribs · Diagram: Keith Rose's Diagrams

- 1- 1c+2c+3c cross RH | set ; repeat
- 9- 1c+3c DbIFig8 round 2c (1c cross down, 3c cast up)
- 17- 1c followed by 2c+3c dance down the middle (2c & 3c divide) ; 1c (leading) +2c+3c dance up
- 25- 1c+2c Rondel (2,1,3).

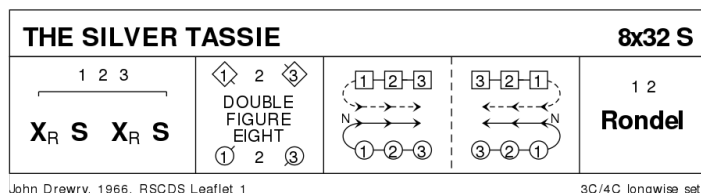

7 THE HIGHLAND FAIR J32 · 2/4L

RSCDS Graded 6 · Crib: E-cribs · Diagram: Keith Rose's Diagrams

- 1- 1c cast off behind own lines ; cast back
- 9- 1c+2c Turn RH ; repeat LH
- 17- 1c followed by 2c lead down the middle ; and up, 2c leading (to 2,1)
- 25- 2c+1c R&L.

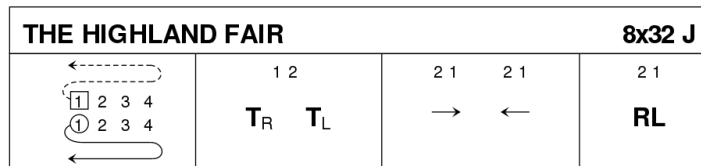

RSCDS Graded Book 1.6

2C/4C longwise set.

8 CAPTAIN HENDERSON'S HORNPIPE R32 · 3/3L

John McLennan: Hunter Valley Book of Dances · Crib: MiniCribs

- 1-8 2s LSh reels of 3 across (Lady with 2s & Man with 3s)
- 9-16 2s reel of 3 on sides giving LSh to person on their Left
- 17-24 1s+2s 1/2 R&L, 1s+3s 1/2 R&L
- 25-32 1s turn RH **while** 2s & 3s cross RH & all circle 6H round to Left

9 AILSA CRAIG S32 · 3/3L

Eric Forbes: Birmingham Book 2004 - Twenty Scottish Country Dances (Compilation of 1973 and 1986) · Crib: E-cribs · Diagram: Keith Rose's Diagrams

- 1- 1c+2c+3c Petronella without setting, to places
- 9- 1c Set, Turn BH (1W twirls) ; 1c set to 2c, turn BH 1/2 to change places (1c twirls)
- 17- 1c set to 3c ; turn BH 1/2 to change places on the side ; 1s cast up to top (2c+3c down)
- 25- 1c+2c+3c 4 hands of Non-crossing Chain (Full turns at top / bottom, 1c start across, 2c with 3c).(to 2,3,1)

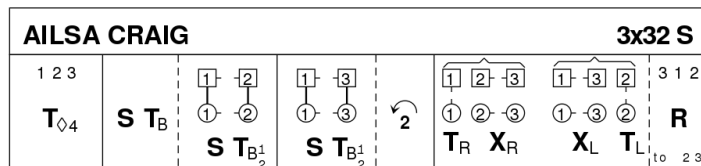

Eric Forbes, 12 SCD (Birmingham 1973)

3C/3C longwise set.

10 FIGURE IT OUT R32 · 3/3L

Roy Goldring: Graded and Social Dances 3 - 16 Dances · Crib: MiniCribs

- 1-8 1s dance 1/2 Fig of 8 round 2s, 1M+2L turn LH 1.1/4 times **while** 1L+2M turn RH 1.1/4 times
- 9-16 1s in prom hold dance reel of 3 across with 2s (RSh to 2M to start) & 1s end in middle facing down
- 17-24 1M dances LH & RH across with 2L+3L **while** 1L dances RH & LH across with 2M+3M 1s & 3s ending in middle facing up
- 25-32 1s followed by 3s dance up & cast to 3rd/2nd places & 1s dance 1/2 Fig of 8 round 3s

11 THE HIGHLAND RAMBLER R40 · 3/4L

Roy Goldring: Silver Jubilee 25 - Leeds Branch · Crib: E-cribs · Diagram: Keith Rose's Diagrams

- 1- 1c long cast to 2pl (2c up on [3-4] ;
1c+3c RHA (2,1,3)
- 9- 2c+1c LHA, 1W faces out ; 1W
followed by 1M cast up round 2W and
down the middle of set, 1W between
3c and 1M between 2c, all facing down
- 17- In lines of 3 down the middle (all swivel R) and up
- 25- 1M followed by 1W dance up, cast round 2W and into 2pl ; 1c turn RH
- 33- Circle6 and back

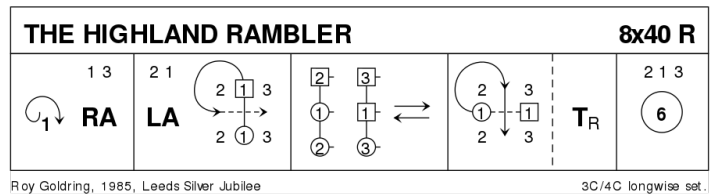

07.11.2018

12 CANADIAN BARN DANCE X16 · 1RR

B Durrands: Collins Pocket Reference: Scottish Country Dancing · Crib: E-cribs

- 1-4 move forwards with 3 runs (outer foot starting) and a hop | repeat backwards
- 5-8 move away from partner with the same step and clap on the hop | and back into ballroom hold
- 9-12 Slip- in-slip-hop in line of dance (RR cclw) | same back
- 13-16 progress RR cclw with half turns in step-hop and open out to begin again

13 AN 'APPY DANCE R32 · 4/4L

John Drewry: The Stoneywood Collection · Crib: MiniCribs

- 1-8 1s & 4s set, cross RH, cast 1 place & 1/2 turn partners 2H
- 9-16 1s+4s slip step down & back
- 17-24 1s followed by 4s dance up, 1s cast to 3rd place as 4s cast to 2nd place & dance 1/2 Figs of 8 round end couples
- 25-32 4s+1s 1/2 turn partner RH, twirl & dance out to own sides, 2s+4s also 1s+3s circle 4H round to left

14 CULLODEN LINKS S32 · 4/4L

John Drewry: *The Diamond Jubilee Collection (Inverness)* · Crib: *MiniCrib*s · Diagram: *Keith Rose's Diagrams*

3s & 4s on opp sides

- 1-8** 1M & 4L dance Figs of 8 on the Mens side **while** 1L & 4M dance Figs of 8 (1s & 4s dance in to start & give hands when passing)
- 9-12** 1s & 4s cross RH & cast in 1 place **while** 2s & 3s 1/2 turn RH & lead up/down to ends. (2)(1)4 3
- 13-16** 1s & 4s dance 1/2 Figs of 8 round end positions as 2s & 3s cast into 1/2 Figs of 8. 2 1(4)(3)
- 17-24** 1s+4s circle 4H round to left 1/2 way & 4L+1M also 4M+1L turn 2H, 4s+1s circle 4H to left once round & turn right about to face up/down
- 25-32** All dance RSh reels of 4 on sides. 2 4(1)(3)

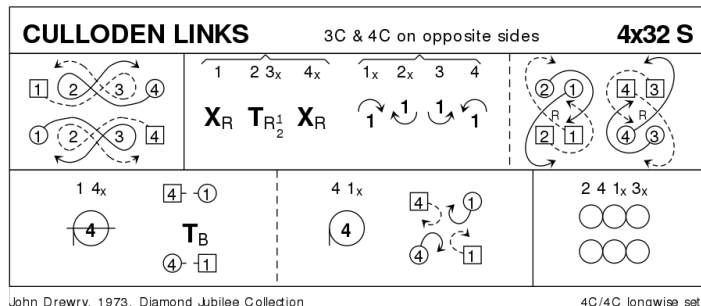

15 ROSNOR ABBEY J40 · 2/4L

Miss Milligan's *Miscellany of Scottish Country Dances* · Crib: *E-cribs* · Diagram: *Keith Rose's Diagrams*

- 1-** 1W+2M turn RH $\frac{3}{4}$ to face each other on midline (M below W) | set ; turn LH back to places, set
- 9-** 1M+2W repeat
- 17-** 1c lead down the middle and up
- 25-** 1c+2c Allemande
- 33-** 2c+1c R&L.

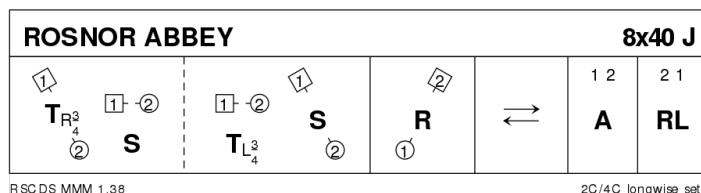

(Note: [1-2] and [9-10] now specify half turns, superseding older instructions.)

16 A DANCE CALLED IRENE S32 · 4/4L

Ron Wallace: *From the Redwood Forest* · Crib: *MiniCrib*s

- 1-8** 1s+2s also 3s+4s circle left, 1s+2s also 3s+4s turn 2H 1.1/2 times on sides
- 9-16** Top 3 Men turn bottom 3 Ladies RH, top 3 Ladies turn bottom 3 Men LH
- 17-24** 1M+4L set & 3/4 turn 2H into centre to face partners who chase clockwise 1/2 way, 4s & 1s set & 3/4 turn RH to 2nd/3rd places own sides
- 25-32** 2s+4s also 1s+3s dance Diamond Poussette

17 DALSTON HALL S40 · 4/4L

John Drewry: *Rondel Book of SCD* · Crib: *MiniCrib*s

- 1-8** 1s cross RH, 1s+2s change places LH on sides, 2s+1s+3s cross RH & set
- 9-16** 2s+1s+3s circle 8H round & back
- 17-24** 1s+3s dance 1/2 RH across, 3s cast to place **while** 1s turn 1/2 RH to 2nd place opposite side, 1s+2s dance 1/2 LH across, 2s cast to top **while** 1s 1/2 turn LH to 2nd place own side facing down
- 25-32** 2s+1s+3s+4s dance Grand Chain
- 33-40** 1s+3s+4s dance reels of 3 on sides (1s give RSh to 3s to start) & 1s dance down to 4th place

18 AN 'APPY DANCE R32 · 4/4L

*John Drewry: The Stoneywood Collection · Crib: MiniCrib*s

- 1-8 | 1s & 4s set, cross RH, cast 1 place & 1/2 turn partners 2H
- 9-16 | 1s+4s slip step down & back
- 17-24 | 1s followed by 4s dance up, 1s cast to 3rd place as 4s cast to 2nd place & dance 1/2 Figs of 8 round end couples
- 25-32 | 4s+1s 1/2 turn partner RH, twirl & dance out to own sides, 2s+4s also 1s+3s circle 4H round to left

19 A DANCE CALLED IRENE S32 · 4/4L

*Ron Wallace: From the Redwood Forest · Crib: MiniCrib*s

- 1-8 | 1s+2s also 3s+4s circle left, 1s+2s also 3s+4s turn 2H 1.1/2 times on sides
- 9-16 | Top 3 Men turn bottom 3 Ladies RH, top 3 Ladies turn bottom 3 Men LH
- 17-24 | 1M+4L set & 3/4 turn 2H into centre to face partners who chase clockwise 1/2 way, 4s & 1s set & 3/4 turn RH to 2nd/3rd places own sides
- 25-32 | 2s+4s also 1s+3s dance Diamond Poussette

20 IT'S JUST FOR FUN J32 · 3/4L

Roy Fidler: RSCDS XXXIII 6 · Crib: E-cribs · Diagram: Keith Rose's Diagrams

- 1- | 1c cross RH | cast off (2c up) ; 1/2 Fig8 round 3cnr, pass Lsh to face 1cnr
- 9- | 1/2 Reel4 with 1cnrs, pass Lsh ; Teapots R (1M+2W+3W (at top) & 1W+2M+3M RHA) finish facing 2cnrs
- 17- | 1/2 Reel4 with 2cnrs, pass Lsh ; Teapots R on own sides (1M+2W+3W & 1W+2M+3M RHA)
- 25- | 1c turn LH 1/2 (1M faces up, 1W down) **while{2}** all cnrs change places RH on sides (polite turn) | 1c dances out the end and L to 2pl **while{4}** 2c+3c set to P and cross RH | All set (2,1,3).

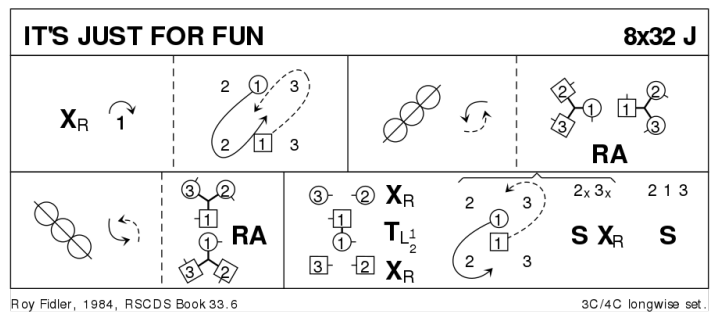

21 GRANVILLE MARKET J32 · 3/4L

Elinor M Vandegrift: A Second Book of Graded Scottish Country Dances · Crib: E-cribs · Diagram: Keith Rose's Diagrams

- 1- | 1c+2c RHA, LHA
- 9- | 1c cross RH | cast (2c up) ; 1/2 Fig8 up to face 1cnr
- 17- | 1c turn 1cnr RH | pass Rsh ; turn 2cnr RH | pass Rsh to (2,1,3)
- 25- | Circle6 and back

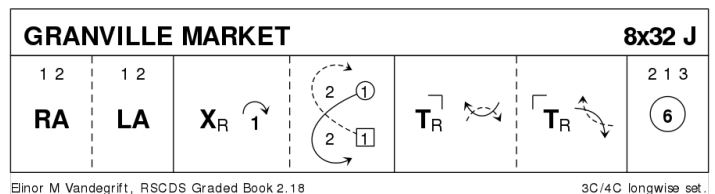

22 MAXWELL'S RANT R32 · 3/4L

David Rutherford: RSCDS XVIII 10 · Crib: E-cribs · Diagram: Keith Rose's Diagrams

- 1- Mirror Reels3 on the sidelines (1c cross down) (1x,2,3)
- 9- 1c cross back into mirror Reels3 on own sides
- 17- 1c cross RH | cast (2c up) ; ½ Fig8 round 2c
- 25- 1c dance down between 3c and cast up to 2pl ; 2c+1c+3c turn RH

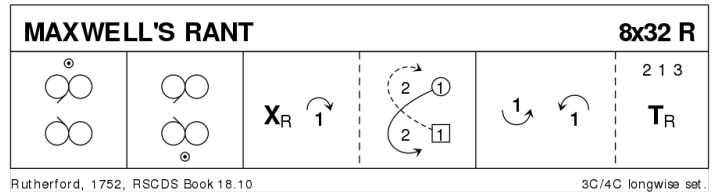

21.11.1018

23 GRANVILLE MARKET J32 · 3/4L

Elinor M Vandegrift: A Second Book of Graded Scottish Country Dances · Crib: E-cribs · Diagram: Keith Rose's Diagrams

- 1- 1c+2c RHA, LHA
- 9- 1c cross RH | cast (2c up) ; ½ Fig8 up to face 1cnr
- 17- 1c turn 1cnr RH | pass Rsh ; turn 2cnr RH | pass Rsh to (2,1,3)
- 25- Circle6 and back

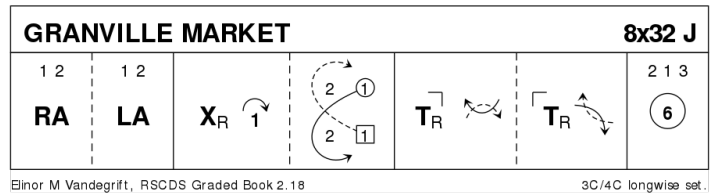

24 SEAGREEN S32 · 3/3L

John Drewry: The Brodie Book · Crib: E-cribs · Diagram: Keith Rose's Diagrams

- 1- 1c+2c+3c set | {1M+3W petronella-turn to finish BtoB between 2c with 1M facing up and 3W facing down ; dance through P's place | cast R to exchanged places} **while**{6} {1W+3M cast clw to other end ; petronella to finish BtoB with 3M facing up and 1W facing down | both dance out to exchanged places (3x,2,1x)}
- 9- All set, circle6 L. On [14], all drop hands, dance into the centre pulling Rsh back to face out, and dance clw to starting places (3x,2,1x)
- 17- 3c+2c+1c repeat figure [1-8] to (1,2,3)
- 25- 2c followed by 1c dance down NHJ between 3c and cast up to 1pl / 2pl ; 1c with 3c following dance up NHJ between 2c and cast off to 3pl / 2pl (to 2,3,1)

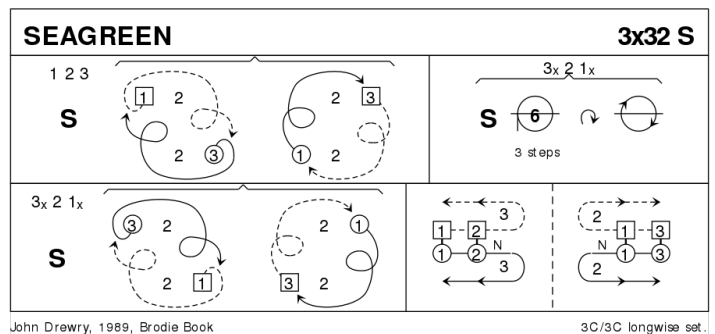

25 IT'S JUST FOR FUN J32 · 3/4L

Roy Fidler: RSCDS XXXIII 6 · Crib: E-cribs · Diagram: Keith Rose's Diagrams

- 1- 1c cross RH | cast off (2c up) ; ½Fig8 round 3cnr, pass Lsh to face 1cnr
 9- ½Reel4 with 1cnrs, pass Lsh ; Teapots R (1M+2W+3W (at top) & 1W+2M+3M RHA) finish facing 2cnrs
 17- ½Reel4 with 2cnrs, pass Lsh ; Teapots R on own sides (1M+2W+3W & 1W+2M+3M RHA)
 25- 1c turn LH ½ (1M faces up, 1W down) **while**{2} all cnrs change places RH on sides (polite turn) | 1c dances out the end and L to 2pl **while**{4} 2c+3c set to P and cross RH | All set (2,1,3).

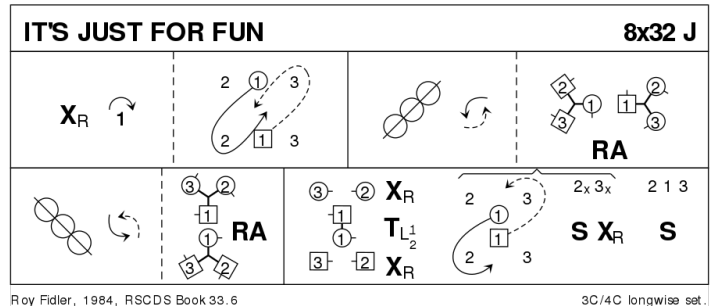

26 MEMORIES OF MARY ANN S32 · 3/3L

Pam Stephens: RSCDS XLVII 7 · Crib: E-cribs · Diagram: Keith Rose's Diagrams

- 1- 1c set | cast off (2c up) ; ½ Reels3 across Lsh to 1cnr (2x,1x,3x)
 9- S&Link3 to lines across ; 1c turn LH to face 1cnr (pos.)
 17- 1c+1cnrs ½ Reel4 , pass Rsh ; repeat with 2cnr, 1c crossing Rsh to (2,1,3)
 25- 3c+1c The Knot (2,3,1)

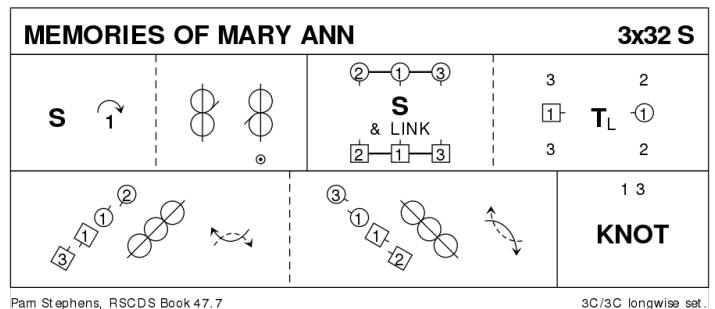

27 LOCH LINNHE S32 · 3/3L

Roy Goldring: Silver Jubilee 25 - Leeds Branch · Crib: MiniCribs

- 1-8 1s & 3s cross RH **while** 2s set, 1s dance reels of 3 on side with 2s+3s (1s dance out & down to start)
 9-16 1s & 3s set to partners **while** 2s cross RH, 1s dance reels of 3 on sides with 2s+3s (1s in & down to start)
 17-24 1M+2L cross RH & set **while** 1L+2M set & cross RH, 1s turn 2H 1.1/2 times
 25-32 1M+3L cross RH & set **while** 1L+3M set & cross RH & all turn 2H

28 FOLLOW YOUR LOVE S32 · 3/3L

Dee Steed: Friendship Dances · Crib: MiniCribs · Diagram: Keith Rose's Diagrams

- 1-8 1L followed by partner cast to 3rd place & cross to opposite side, all set & cross RH
 9-16 1M followed by partner cast up to top & cross to opposite side sides, all set & cross LH
 17-24 1s lead down for 2 steps, set, lead up & turn 2H (2s dance in for...)
 25-32 1s+2s dance 1/2 Diamond Poussette, 1s+3s dance 1/2 Diamond Poussette

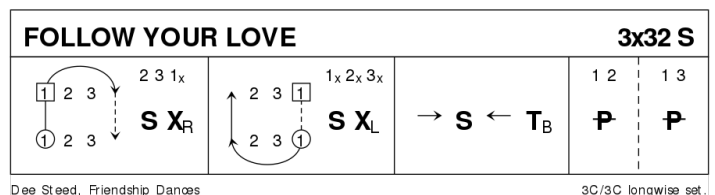

29 GRANVILLE MARKET J32 · 3/4L

Elinor M Vandegrift: A Second Book of Graded Scottish Country Dances · Crib: E-cribs · Diagram: Keith Rose's Diagrams

- 1- 1c+2c RHA, LHA
- 9- 1c cross RH | cast (2c up) ; ½ Fig8 up to face 1cnr
- 17- 1c turn 1cnr RH | pass Rsh ; turn 2cnr RH | pass Rsh to (2,1,3)
- 25- Circle6 and back

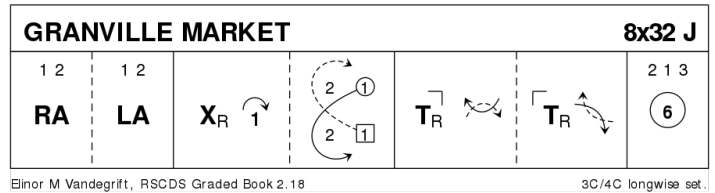

30 INVERNEILL HOUSE R32 · 3/4L

John Drewry: RSCDS XXXV 2 · Crib: E-cribs · Diagram: Keith Rose's Diagrams

- 1- 1c+2c ½ DbIFig8 (to start, 1c cross down and 2c dance up, 2c finish facing out) ; 1c dance down NHJ between 3c and cast up to 2plx **while** 2c cast up and stand (2x,1x,3)
- 9- 1c+3c ½ DbIFig8 (1c cross down and 3c dance up) ; 1c dance up NHJ between 2c and cast off to 2pl own side (2x,1,3x)
- 17- 1c Petronella {8} (to 2x,1x,3x)
- 25- 2c+3c Petronella {8} **while** 1c casts Rsh back | cross (M / W between 3c /2c) ; cast to 2pl | set with 2c+3c (2,1,3)

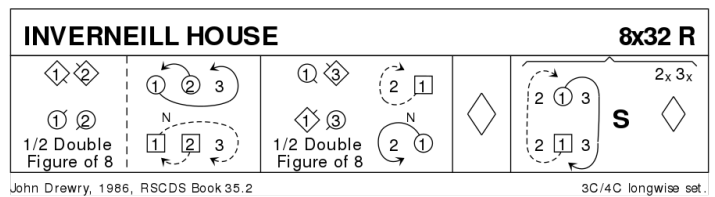

31 SUGAR CANDIE S32 · 3/4L

RSCDS XXVI 9 · Crib: E-cribs · Diagram: Keith Rose's Diagrams

- 1- 1c set | cast off (2c up), pass Lsh and cast R round 1cnr, to finish BtoB in the centre, M facing down, W up
- 9- 1W+2c & 1M+3c circle3, at end 1c swivels R to face P ; 1c set, turn ¾ BH to face 1cnrs (open out with 1M using RH to assist P)
- 17- Turn CPCP
- 25- Reels3{6} with corners, Lsh to 1cnr, 1c cross RH to (2,1,3)

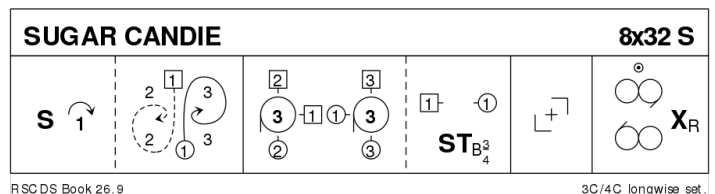

32 IT'S JUST FOR FUN J32 · 3/4L

Roy Fidler: RSCDS XXXIII 6 · Crib: E-cribs · Diagram: Keith Rose's Diagrams

- 1- 1c cross RH | cast off (2c up) ; ½ Fig8 round 3cnr, pass Lsh to face 1cnr
- 9- ½ Reel4 with 1cnrs, pass Lsh ; Teapots R (1M+2W+3W (at top) & 1W+2M+3M RHA) finish facing 2cnrs
- 17- ½ Reel4 with 2cnrs, pass Lsh ; Teapots R on own sides (1M+2W+3W & 1W+2M+3M RHA)
- 25- 1c turn LH ½ (1M faces up, 1W down) **while**{2} all cnrs change places RH on sides (polite turn) | 1c dances out the end and L to 2pl **while**{4} 2c+3c set to P and cross RH | All set (2,1,3).

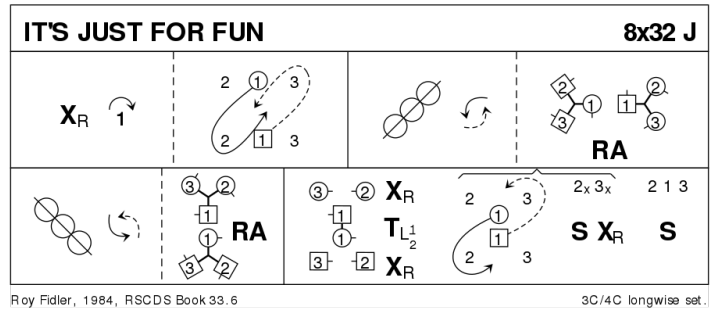

33 IT WISNAE ME S32 · 4/4L

Marjorie Macrae: RSCDS XLVII 10 · Crib: E-cribs · Diagram: Keith Rose's Diagrams

3c+4c cross on second chord (1,2,3x,4x)

- 1- 1c+4c cross RH, cast (2c+3c step to end) ; ½ Fig8 round end cpl (2,1,4x,3x)
- 9- Modified Half Grand Chain: 2c & 3c turn P RH 1½ **while** on sideline 1c+4c turn RH 1½ {3}, all turn next dancer LH ½ {1} (4x,2x,3,1) ; repeat (3,4,1x,2x)
- 17- Reels4 on the sidelines (3,4,1x,2x)
- 25- 3c+2c chase ½ clw **while**{4} 4c+1c LHA ; 2c+4c & 1c+3c RHA (2,4,1x,3x)

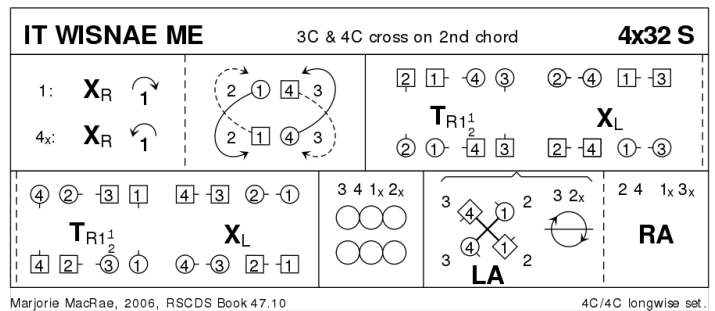

05.12.2018

34 GRANVILLE MARKET J32 · 3/4L

Elinor M Vandegrift: A Second Book of Graded Scottish Country Dances · Crib: E-cribs · Diagram: Keith Rose's Diagrams

- 1- 1c+2c RHA, LHA
- 9- 1c cross RH | cast (2c up) ; ½ Fig8 up to face 1cnr
- 17- 1c turn 1cnr RH | pass Rsh ; turn 2cnr RH | pass Rsh to (2,1,3)
- 25- Circle6 and back

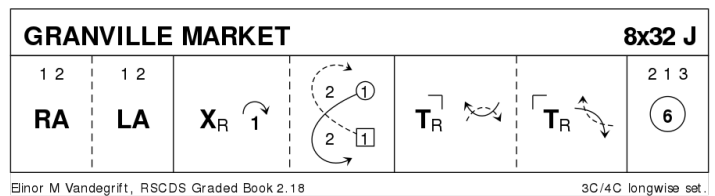

35 THE HAZEL TREE J32 · 3/4L

John Drewry: *New Dances by John Drewry 2005* · Crib: *E-cribs* · Diagram: *Keith Rose's Diagrams*

- 1- 1c+2c Espagnole, 1c finishing facing 1cnr
- 9- 1c turn 1cnr RH, pass Rsh ; turn 3cnr LH, pass Lsh (cnrs dance for {4})
- 17- Turn 2cnr RH, pass Rsh ; turn 4cnr LH, pass Lsh to 2plx side by side facing down
- 25- Lead LHJ between 3c, cross and cast to 2pl ; All C turn RH

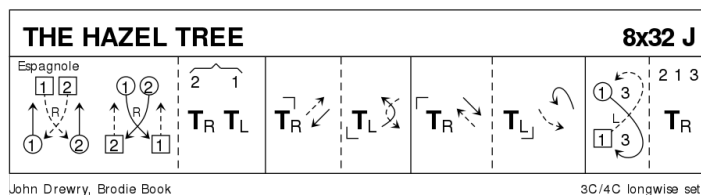

Espagnole: both W lead RHJ to M side, cross and cast back to exchanged places while{} Men cross to W side, lead RHJ back to M side and cross to exchanged places ; all turn P EH (2,1)

36 SEAGREEN S32 · 3/3L

John Drewry: *The Brodie Book* · Crib: *E-cribs* · Diagram: *Keith Rose's Diagrams*

- 1- 1c+2c+3c set | {1M+3W petronella-turn to finish BtoB between 2c with 1M facing up and 3W facing down ; dance through P's place | cast R to exchanged places} **while**{6} {1W+3M cast clw to other end ; petronella to finish BtoB with 3M facing up and 1W facing down | both dance out to exchanged places (3x,2,1x)
- 9- All set, circle6 L. On [14], all drop hands, dance into the centre pulling Rsh back to face out, and dance clw to starting places (3x,2,1x)
- 17- 3c+2c+1c repeat figure [1-8] to (1,2,3)
- 25- 2c followed by 1c dance down NHJ between 3c and cast up to 1pl / 2pl ; 1c with 3c following dance up NHJ between 2c and cast off to 3pl / 2pl (to 2,3,1)

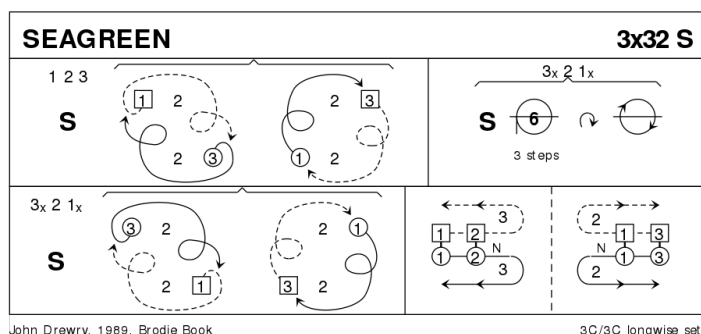

37 BACK TO THE FIRESIDE R32 · 3/4L

Roy Goldring: *RSCDS XXXVIII 4* · Crib: *E-cribs* · Diagram: *Keith Rose's Diagrams*

- 1- 3c followed by 1c dance down the middle | set ; dance up the middle, 1c cast off to 3pl **while**{2} 3c dance up to 1pl (3,2,1)
- 9- »pick-up chain«, from below: 1c cross RH, 1c+2c change places LH ; 1c+3c change places RH **while**{2} 2c cross RH ; 1c cross LH **while**{2} 3c+2c change places LH (to 1, 2x, 3)
- 17- 1c+2c set advancing to join NH in a circle | releasing hands, 1c+2c Petronella one place R ; Set NHJ | repeat petronella, to sidelines (2,1x,3)
- 25- 1c ½ Fig8 L (W up, M down) ; All turn RH (2,1,3)

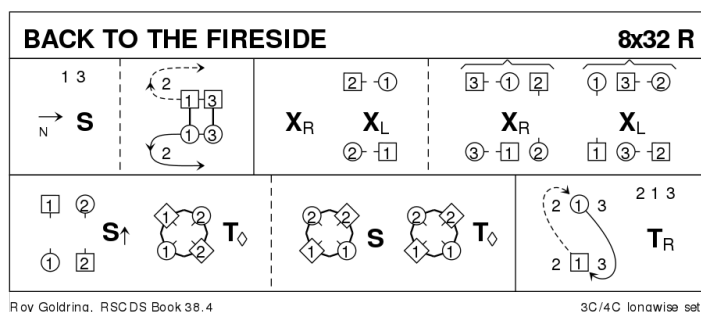

38 THE BACK O' BENNACHIE R32 · 2/4L

John M Duthie: Eight Scottish Country Dances · Crib: E-cribs · Diagram: Keith Rose's Diagrams

- 1- 1c+2M Reel3 across the dance, 2M starting by giving Rsh to 1W
- 9- 1c+2W Reel3 across the dance, 2W starting by giving Lsh to 1M
- 17- 1W+2M cross RH, 1M+2W cross RH ; 2c+1c dance half R&L
- 25- 1c cross RH, cast one place ; dance ½ Fig8 round 2c

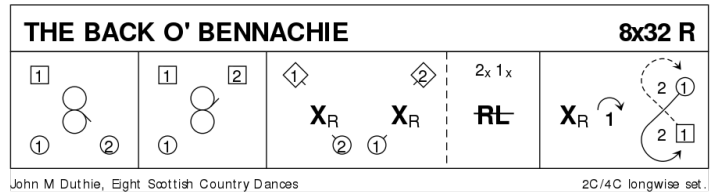

39 SUGAR CANDIE S32 · 3/4L

RSCDS XXVI 9 · Crib: E-cribs · Diagram: Keith Rose's Diagrams

- 1- 1c set | cast off (2c up), pass Lsh and cast R round 1cnr, to finish BtoB in the centre, M facing down, W up
- 9- 1W+2c & 1M+3c circle3, at end 1c swivels R to face P ; 1c set, turn ¾ BH to face 1cnrs (open out with 1M using RH to assist P)
- 17- Turn CPCP
- 25- Reels3{6} with corners, Lsh to 1cnr, 1c cross RH to (2,1,3)

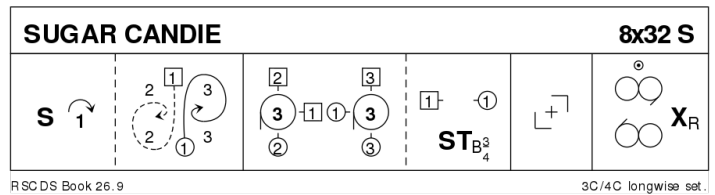

12.12.2018

40 MAXWELL'S RANT R32 · 3/4L

David Rutherford: RSCDS XVIII 10 · Crib: E-cribs · Diagram: Keith Rose's Diagrams

- 1- Mirror Reels3 on the sidelines (1c cross down) (1x,2,3)
- 9- 1c cross back into mirror Reels3 on own sides
- 17- 1c cross RH | cast (2c up) ; ½ Fig8 round 2c
- 25- 1c dance down between 3c and cast up to 2pl ; 2c+1c+3c turn RH

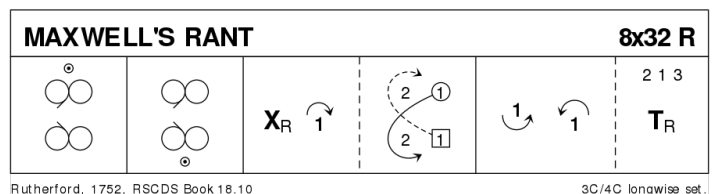

41 SEAGREEN S32 · 3/3L

John Drewry: *The Brodie Book* · Crib: *E-cribs* · Diagram: *Keith Rose's Diagrams*

- 1- 1c+2c+3c set | {1M+3W petronella-turn to finish BtoB between 2c with 1M facing up and 3W facing down ; dance through P's place | cast R to exchanged places} **while**{6} {1W+3M cast clw to other end ; petronella to finish BtoB with 3M facing up and 1W facing down | both dance out to exchanged places (3x,2,1x)

- 9- All set, circle6 L. On [14], all drop hands, dance into the centre pulling Rsh back to face out, and dance clw to starting places (3x,2,1x)

- 17- 3c+2c+1c repeat figure [1-8] to (1,2,3)

- 25- 2c followed by 1c dance down NHJ between 3c and cast up to 1pl / 2pl ; 1c with 3c following dance up NHJ between 2c and cast off to 3pl / 2pl (to 2,3,1)

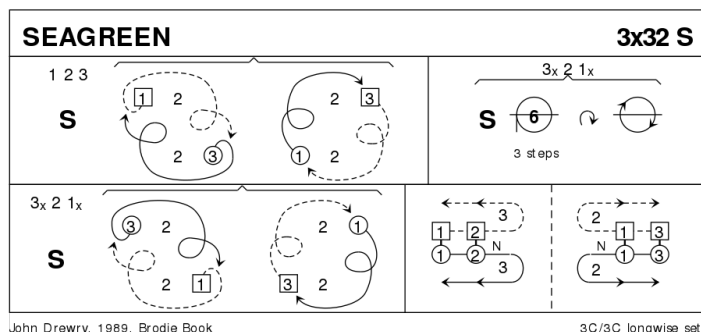

John Drewry, 1989, Brodie Book

3C/3C longwise set.

42 THE HAZEL TREE J32 · 3/4L

John Drewry: *New Dances by John Drewry 2005* · Crib: *E-cribs* · Diagram: *Keith Rose's Diagrams*

- 1- 1c+2c Espagnole, 1c finishing facing 1cnr

- 9- 1c turn 1cnr RH, pass Rsh ; turn 3cnr LH, pass Lsh (cnrs dance for {4})

- 17- Turn 2cnr RH, pass Rsh ; turn 4cnr LH, pass Lsh to 2plx side by side facing down

- 25- Lead LHJ between 3c, cross and cast to 2pl ; All C turn RH

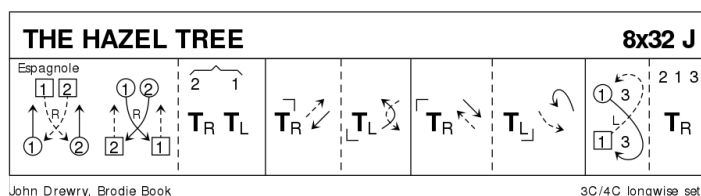

John Drewry, Brodie Book

3C/4C longwise set.

Espagnole: both W lead RHJ to M side, cross and cast back to exchanged places while{} Men cross to W side, lead RHJ back to M side and cross to exchanged places ; all turn P EH (2,1)

43 BACK TO THE FIRESIDE R32 · 3/4L

Roy Goldring: *RSCDS XXXVIII 4* · Crib: *E-cribs* · Diagram: *Keith Rose's Diagrams*

- 1- 3c followed by 1c dance down the middle | set ; dance up the middle, 1c cast off to 3pl **while**{2} 3c dance up to 1pl (3,2,1)

- 9- »pick-up chain«, from below: 1c cross RH, 1c+2c change places LH ; 1c+3c change places RH **while**{2} 2c cross RH ; 1c cross LH **while**{2} 3c+2c change places LH (to 1, 2x, 3)

- 17- 1c+2c set advancing to join NH in a circle | releasing hands, 1c+2c Petronella one place R ; Set NHJ | repeat petronella, to sidelines (2,1x,3)

- 25- 1c ½ Fig8 L (W up, M down) ; All turn RH (2,1,3)

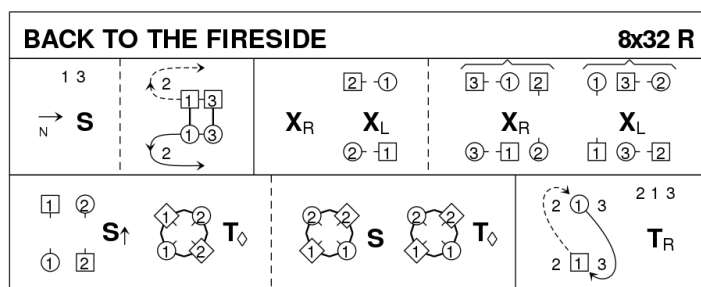

Roy Goldring, RSCDS Book 38.4

3C/4C longwise set.

44 LINNEA'S STRATHSPEY S32 · 3/4L

Tim Wilson: RSCDS XLVII 2 · Crib: E-cribs · Diagram: Keith Rose's Diagrams

- 1- 1c set | cast off (2c up), cross Lsh and cast R round 1cnr to face 1cnr
- 9- SetH&G, at end pass Rsh to face out in 2pl
- 17- [Chaperoned Chain Progression] 1c cast $\frac{1}{4}$ clw round set **while** {} 2c & 3c Turn RH $\frac{3}{4}$ | 2M+3W turn $1\frac{1}{2}$ LH **while** {} the others promenade $\frac{1}{2}$ clw round set | 3c+2c turn RH $\frac{3}{4}$ and face up **while** {} 1c cast $\frac{1}{4}$ clw to meet in 2pl, for
- 25- 3c+1c+2c Allemande (2,1,3)

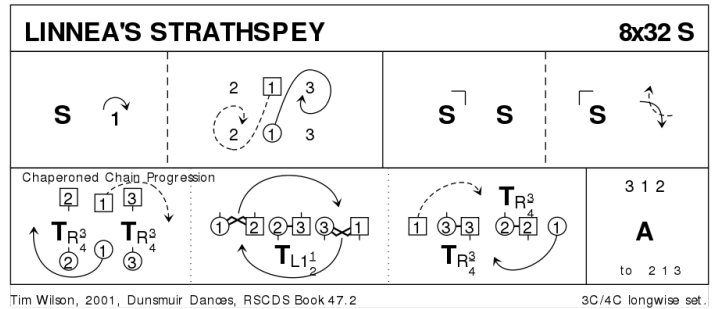

45 SUGAR CANDIE S32 · 3/4L

RSCDS XXVI 9 · Crib: E-cribs · Diagram: Keith Rose's Diagrams

- 1- 1c set | cast off (2c up), pass Lsh and cast R round 1cnr, to finish BtoB in the centre, M facing down, W up
- 9- 1W+2c & 1M+3c circle3, at end 1c swivels R to face P ; 1c set, turn $\frac{3}{4}$ BH to face 1cnrs (open out with 1M using RH to assist P)
- 17- Turn CPCP
- 25- Reels3{6} with corners, Lsh to 1cnr, 1c cross RH to (2,1,3)

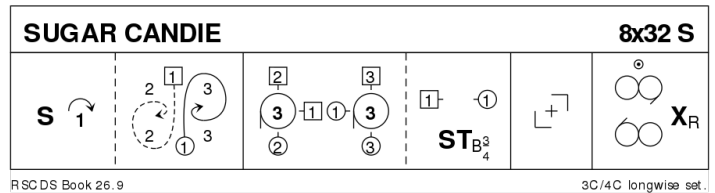

46 THE BACK O' BENNACHIE R32 · 2/4L

John M Duthie: Eight Scottish Country Dances · Crib: E-cribs · Diagram: Keith Rose's Diagrams

- 1- 1c+2M Reel3 across the dance, 2M starting by giving Rsh to 1W
- 9- 1c+2W Reel3 across the dance, 2W starting by giving Lsh to 1M
- 17- 1W+2M cross RH, 1M+2W cross RH ; 2c+1c dance half R&L
- 25- 1c cross RH, cast one place ; dance $\frac{1}{2}$ Fig8 round 2c

