

# 2019\_09\_21 Tageskurs Denkendorf Social Dance

## 1 EH3 7AF J32 · 3/4L

Roy Goldring: RSCDS XL 6 · Crib: E-cribs · Diagram: Keith Rose's Diagrams

- 1- 1c lead down the middle and up, on [8] 2c+3c step in for
- 9- 1c+2c+3c Promenade, at end 1c cast off (to 2,1,3)
- 17- 1c cross Rsh | turn 1c nr RH ; cross up/dn Rsh | turn 2c nr RH (2,1x,3) |
- 25- 2c+1M & 1W+3c RHA ; 1c ½ Fig 8 Rsh round 4c nr (2,1,3)

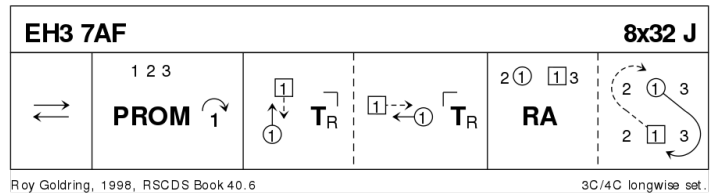

## 2 CHERRYBANK GARDENS S32 · 3/3L

John Drewry: Bankhead Book Part 1 · Crib: E-cribs · Diagram: Keith Rose's Diagrams

- 1- 1c+2c set | petronella in tandem ; repeat (2x,1x,3)
- 9- 2c+1c set | 2c cross RH **while{2}** 1c cross LH ; 1W+2c & 1M+3c RHA (Teapots) to sidelines (2,1,3)
- 17- 1c+3c S&Link ; 3c+1c circle4 left, end 3c facing 1c for
- 25- G-Chain (2c cross to start) (2, 3, 1)

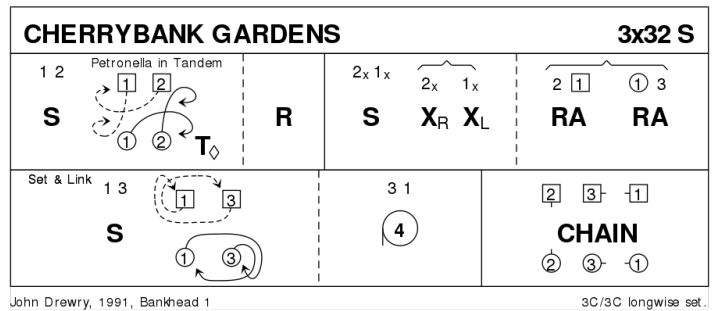

## 3 MARY ERSKINE R32 · 3/4L

Roy Goldring: A Second Book of Graded Scottish Country Dances · Crib: E-cribs · Diagram: Keith Rose's Diagrams

- 1- 1c (start inwards)+2c mirror turn on sides 1½ ; 1c cast behind 3c | dance up to 2pl BtoB facing own side for
- 9- DTr, but on [15-16], 1c (on opposite side) set turning right about to face P
- 17- 1c BHJ, slip down the middle & up to 2pl in the centre, facing up
- 25- 1W+2M+3M LHA **while{}** 1M+2W+3W RHA ; 1c ½ Fig8 up round 2c (to 2,1,3)

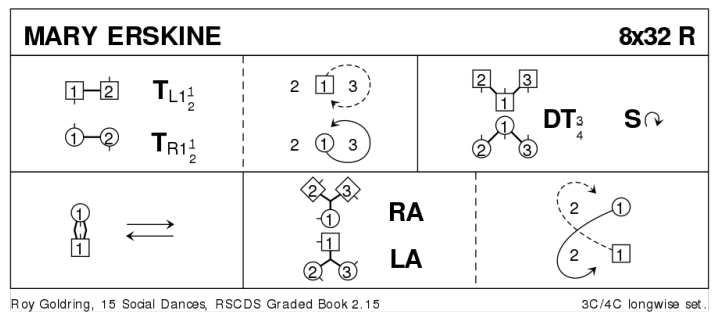

## 4 THE BEES OF MAGGIEKNOCKATER J32 · 4/4L

John Drewry: *The Canadian Book of Scottish Country Dances* · Crib: *E-cribs* · Diagram: *Keith Rose's Diagrams*

- 1-- 1c cross RH | cast off (2c up) ; 1c+3c RHA, finish as pairs 1M+3W & 3M+1W facing out on W/M side in promhold
- 9-- Pairs+ 2c+4c Rsh ½Reels3 on sides ; pairs meet & take P in promhold for Lsh ½Reels3 on sides
- 17-- Meet and repeat (as pairs Rsh ½Reels3 ; with P Lsh ½Reels3)
- 25-- 1c (passing inside) turn 3c 1½ Easy Hand ; 1c cross and passing inside turn 4c EH 1½ (to 2,3,4,1)

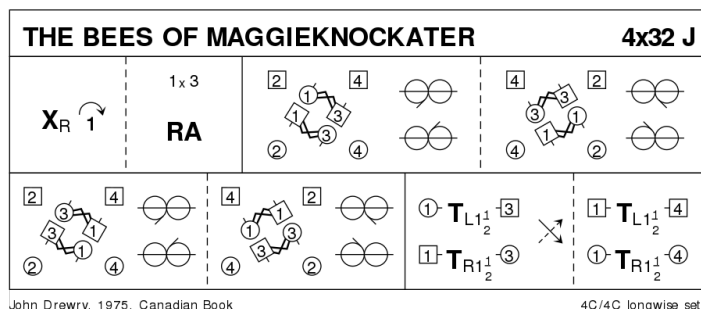

## 5 DANCE OF LOVE S32 · 3/3L

Aymeric Fromherz · Crib: *E-cribs* · Diagram: *Keith Rose's Diagrams*

- 1-- All Turn Halfway and Cast ; chase clw ½ (3,2,1)
- 9-- 2c+1c Tourbillon (3,1,2)
- 17-- 1c »Figure of Love« [1c loop LSh round 1cnrs[pos] to centre, touch P BH, pull LSh back to face opp sides, loop LSh round 2cnrs[pos] to original places] (3,1,2)
- 25-- Reels3 across, 1c LSh to 1cnrs[pos] (3,1,2)

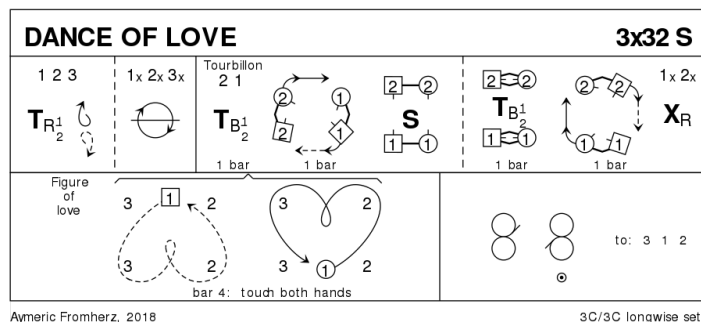

## 6 HASTE TO THE WEDDING J32 · 2/4L

RSCDS XXV 6 · Crib: *E-cribs* · Diagram: *Keith Rose's Diagrams*

- 1-- 1c turn RH ½ | lead down ; turn RH ½ | lead up to place
- 9-- 2c repeat
- 17-- 1c+2c set | ½ RHA ; set | ½ LHA into
- 25-- 1c+2c Poussette

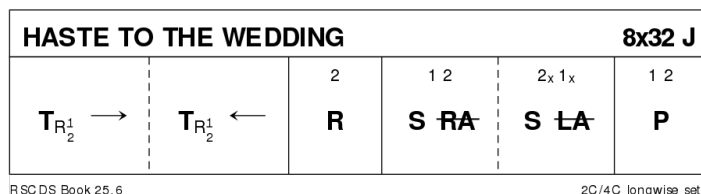

## 7 MAIRI'S WEDDING R40 · 3/4L

James B Cosh: *Twenty Two SCD · Crib: E-cribs · Diagram: Keith Rose's Diagrams*

- 1- 1c turn RH | cast (2c up) ; turn LH to face 1cnrs
- 9- 1c ½Reel4 with 1cnrs (pass P Lsh) ; Repeat with 2cnrs
- 17- Repeat with 3cnrs (1cnr person) ; Repeat with 4cnrs (2cnr person)
- 25- 1W+2c & 1M+3c Reels3 across, Lsh to 1cnr
- 33- 2c+1c+3c circle6 and back

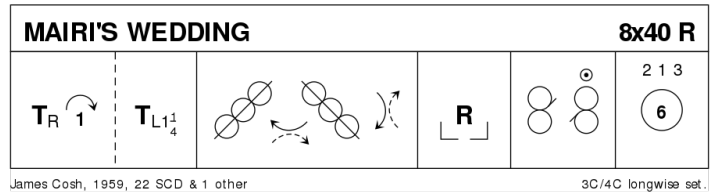

Note: Cosh explicitly tells 1c to pass Lsh in [9-24]; however the Rsh pass is quite common, and nicknamed »Mairi's Divorce«.

## 8 JOHNNIE WALKER M128 · 4S

Norman & Helen Robson: *The Whisky Collection · Crib: E-cribs · Diagram: Keith Rose's Diagrams*

Strathspey

- 1- Circle8 and back
- 9- Set to and turn corners RH ; set to and turn P LH
- 17- 1c+3c advance & meet opposite person {1}, lead out between side couple, cross and dance to opposite place ; turn P 1½ RH (3,2,1,4)
- 25- 2c+4c repeat (to 3,4,1,2)
- 33- All W Petronella Turn into next W place to the R | All set ; repeat to W in original places
- 41- All M repeat Petronella Turns and setting back to original places
- 49- G-Chain (one step per hand)
- 57- Promenade (Allemande hold) cclw round the set, to places

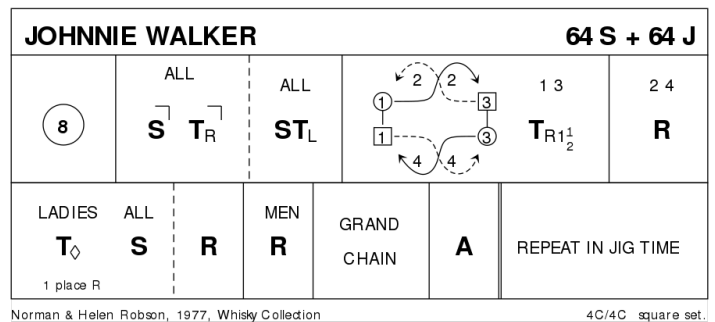

Jig

- 65-128 | Repeat all, end with women in the centre facing P for bow/curtsey.

## 9 J. B. MILNE R32 · 3/4L

Hugh Foss: *Angus Fitchet Scottish Dance Album · Crib: E-cribs · Diagram: Keith Rose's Diagrams*

- 1- 1M+2W set advancing and turn RH ; 1W+2M repeat
- 9- 1c set advancing | turn BH and open upwards ; cast off one (2c up), Petronella Turn to: 1M between 3c and 1W between 2c
- 17- 1c set, turn ¾ RH, set, turn ¾ RH, **while**{8} 2c+3c pass RH on the sides, set, cross RH, set
- 25- 1c set, pass RH, cast R into 2pl, **while** {6} 2c+3c pass RH on the sides, set ; cross RH | all set. (2,1,3)

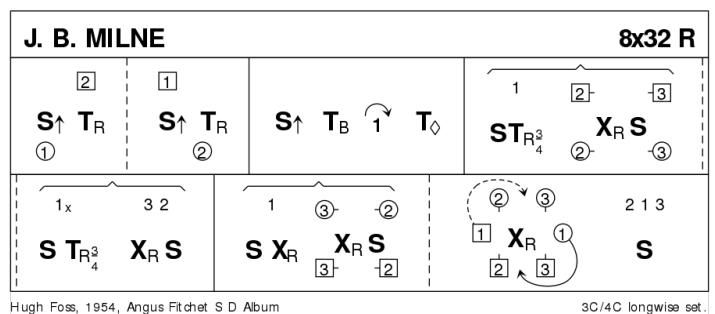

In 17-32, the corners traditionally set one bar to the person you just passed, then one bar to the next person to pass. In a variant for [19-24] 1c turns BH in PdB.

## 10 ROARING JELLY J32 · 3/4L

Hugh Foss: Glendarroch Scottish Dance Sheets · Crib: E-cribs · Diagram: Keith Rose's Diagrams

- 1- 1c cross RH | cast off (2c up) ; cross RH, 1c casts R round 3c to finish in line across between 2c and 3c
- 9- Circle6 and back
- 17- 1c change places up/dn RH | Fig8 round 4c and 1c, (start Rsh), finish on sideline facing 2c
- 25- 1c Reels3{6} on opposite sides (Rsh to 2c) | cross RH

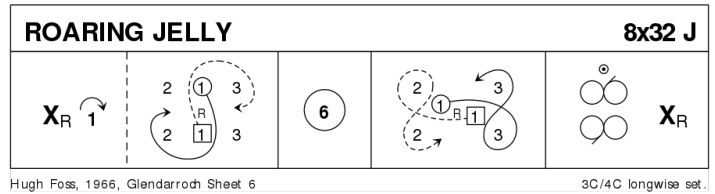

## 11 MACDONALD OF THE ISLES S32 · 3/3L

Derek Haynes: Carnforth Collection of SC Dances 2 · Crib: E-cribs · Diagram: Keith Rose's Diagrams

- 1- 2c diagonal Reel4 with 1cnrs, at end dance Lsh round P to face 2cnr
- 9- 2c diagonal Reel4 with 2cnr (2cnr loop by the R) (to 1,2,3)
- 17- 1c+2c+3c »snowball« G-Chain (1c begin, 2 bars per hand) (to 3,2x,1)
- 25- 3c+2c ½ R&L ; 3c ½ Fig8 R (3M up, 3W down) (2,3,1)

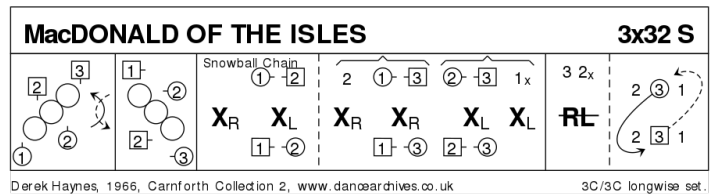

## 12 THE DEIL AMANG THE TAILORS R32 · 3/4L

RSCDS XIV 7 · Crib: E-cribs · Diagram: Keith Rose's Diagrams

- 1- 1c+2c set, ½ RHA ; set, ½ LHA
- 9- 1c lead down the middle and up, 2c step in for
- 17- 1c+2c Allemande
- 25- 2c+1c+3c circle6 and back.

